

KWIK PLYTM

APPLICATION GUIDE

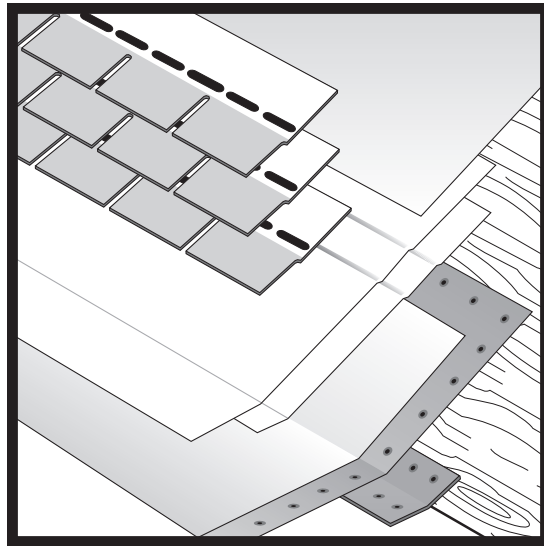

Additional copies of this guide are available through your Kwik Ply distributor or by calling customer service at 1 (800) 457-4056

Please review the list of tools on page 15 and Appendix A for a directory of manufacturers supplying other materials necessary to complete your project.

APPLICATION OVERVIEW

Kwik Ply products may be installed over various substrates. Before installation can begin, the substrate, its condition and the assembly components must be identified so that proper materials can be ordered to complete a successful application. Assembly parts are interdependent and selection of the proper materials is an important procedure

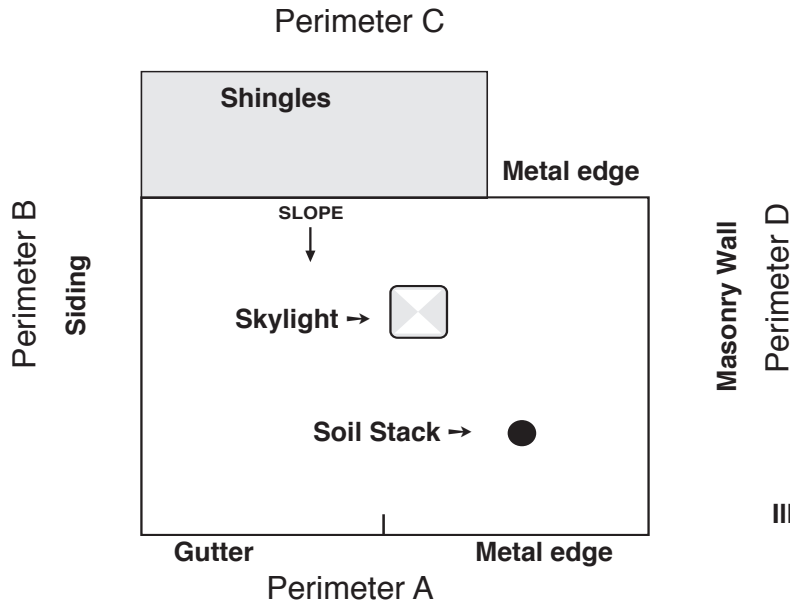

Illus. 2.

in a successful application. The sample project (see illustration 2) has an existing roof which must be removed due to wet felts and moisture trapped in the felts and deck. One sheet of rotted plywood must be replaced. In the perimeter of the roof area, a gutter and metal edge are located at the bottom of the slope (perimeter A). Direction of the slope is indicated by an arrow which points to the low point in the roof. To the left, a wooden framed wall clad with siding is shown (perimeter B). At the top of the illustration a steep shingle area ties into the low slope roof (perimeter C) Also, a short section of metal edge is used between the shingle area and the masonry wall. To the right, a masonry wall extends all along that edge of the roof (perimeter D). In the field of the roof two projections are in place: a soil stack four inches in diameter and a skylight with dimensions of 2' x 2'. Each of these terminations and projections will be addressed in the pages ahead and generally the order in which they will be encountered in your sample installation.

All of the details in this guide may not apply to your specific application. In fact this application has details that would be encountered on more than just one home. This makes it a good example but a more complicated application. Extract the information that applies to your application.

Do not install when the ambient temperature is below 45°F or when fog, mist or imminent rain is forecast. In cold weather applications use of a hot air blower, not a torch, is recommended.

Most residential and light commercial buildings are constructed with a wooden deck, normally plywood. Illustration 3 shows a wood deck assembly with a plywood deck and a ply of Kwik Base nailed to the plywood.

Illustration 4 shows primer being applied over the base sheet. Illustration 5 shows the plywood deck, Kwik Base mechanically attached with large head roofing nails,

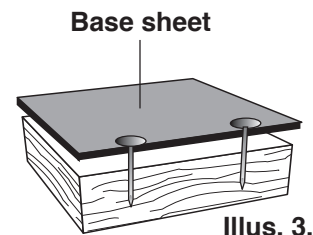

Illus. 3.

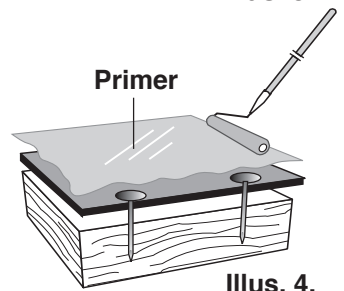

Illus. 4.

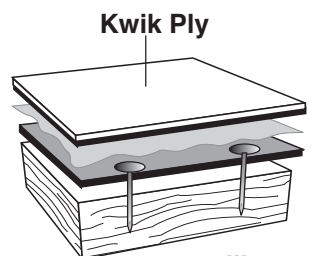

Illus. 5.

primer application to the Kwik Base and then Kwik Ply installed over it. The large head roofing nails must be metal and have a flat instead of domed head as shown in Illustration 6. Nailing the base sheet to the plywood must be done in a staggered pattern which is shown in illustration 7. The layout procedure is covered further on pages 4 through 5.

SAMPLE APPLICATION PROCEDURES

For the purposes of this guide we will begin the sample application by assuming that necessary repairs have been made to the plywood deck, and it is now dry, in good condition and all existing roofing materials have been removed from it.

KWIK BASE INSTALLATION

Kwik Base, or an equivalent base sheet, is the first membrane to be installed and is nailed to the plywood deck using large head roofing nails as shown in illustration 6. The first roll of material —the starter sheet —should always be positioned at the low area on the roof, which in this sample application is along the building edge where the gutter and metal edge are located. When installing the base sheet, start with a piece that has been cut to 16 inches wide and runs the entire length of the roof. This will allow the top ply (Kwik Ply) to be installed over the Kwik Base so that its laps will not be directly under the Kwik Ply laps. This pattern is adequate for up to seven courses of Kwik Ply. The base sheet should butt up against walls or projections and be no more than 1/4 inch from them.

To position the 16 inch-wide Kwik Base, strike a chalk line on the deck 14 inches in from the roof edge and along the entire roof length parallel to the edge. Place the starter sheet with the lay line edge square to the chalk line and along the entire length. This

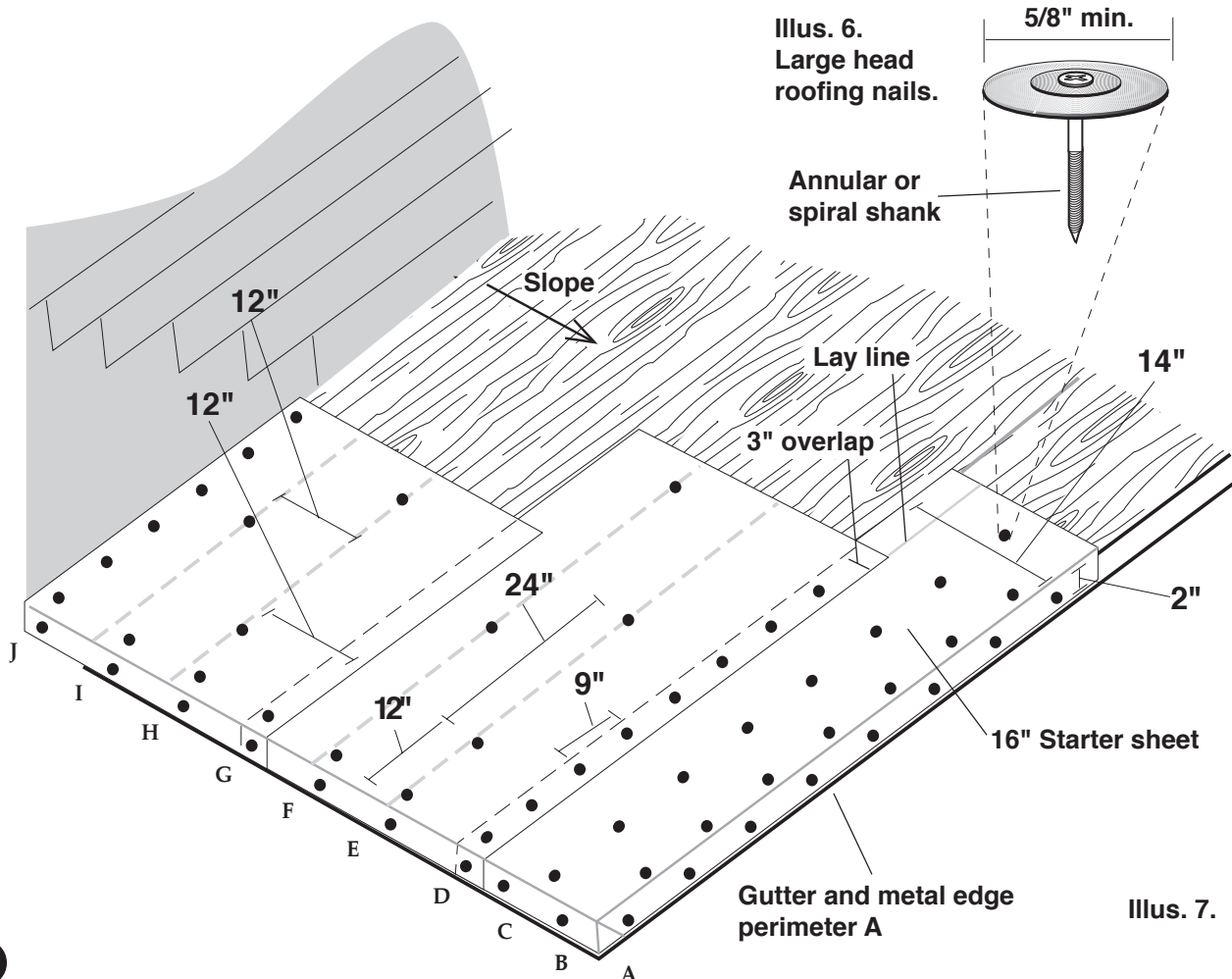
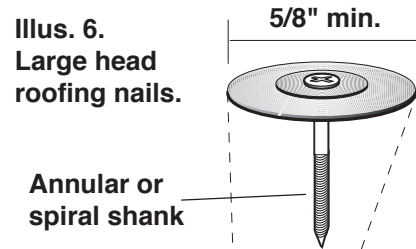

Illus. 7.

Your purchase of Kwik Ply as a high quality roofing material is the first step in creating long term waterproofing protection for your property. Kwik Ply products are quick, easy, safe, and clean products to install using basic hand tools found in most home workshops. Applicators with basic mechanical skills, and following the instructions and references given in this guide, can complete a professional looking roof project.

In the paragraphs below, Kwik Ply and Kwik Base membranes are described in a general way. Other literature is available for these products to provide more specific physical properties information.

Kwik Ply is a self adhered roofing membrane designed for use on residential and light commercial buildings provided the area installed does not exceed five thousand square feet. When Kwik Ply is to be used on large projects, a review of project specifications by the Hyload Technical Department must be completed before the bidding process begins.

Kwik Ply is normally installed in a smooth surface configuration with completion of the laps created by overlapping adjacent membranes using the painted lay lines as a guide. Note that illustration 1 shows a painted line on the top of the Kwik Ply roll, which is called a lay line. It is located 3" in from the edge and runs the entire length of the roll. This line is used to align and install the second and subsequent courses of membrane as you are installing Kwik Ply up the slope between the picture frame lines.

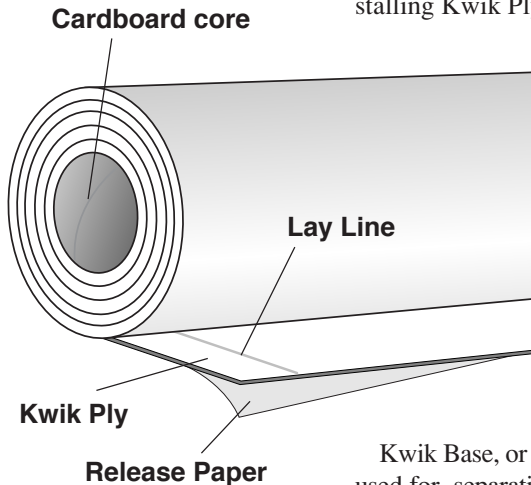

Kwik Ply is packaged in roll form wrapped around a cardboard core. Release paper, installed on the adhesive side of the membrane, prevents the membrane from sticking to itself when rolled and packaged in the shipping box. See illustration 1.

Standard rolls have one hundred square feet of membrane, are three feet by thirty-four feet, and weigh thirty-four pounds. A special two hundred square foot roll is available, three feet by sixty-seven feet, and weighs seventy-two pounds. Cut width rolls, sized 4," 6," 9," 12," & 18," in either 34' or 67' lengths, are available for flashing or repair materials.

Kwik Base, or the recommended NRCA base sheet outlined below, are nailable base sheets used for separating the Kwik Ply from the substrate. Proper installation of one of these base sheets is necessary in order to obtain the Kwik Ply material warranty for your project.

Illus. 1.

The National Roofing Contractors Association (NRCA) recommends a Number 40 asphalt-saturated and coated organic felt base sheet meeting or exceeding ASTM D-2626 be used over wood decks when a base sheet is mechanically fastened. They comment that: Coated base sheets work well to separate the roof from the substrate. They are also incorporated where the project requires a tougher or thicker base to cushion the membrane over minor irregularities, to help span joints in the deck or substrate immediately below the roof membrane, and where mechanical fastening of the base ply is required.

Mechanically attached base sheets serve as a separation layer between the roof deck and the membrane so that the membrane may move (thermally) independently from the roof deck as well as vent moisture laterally that may have been trapped or will be generated in the building environment. Used appropriately, a base sheet can help eliminate buckling and splitting problems.

On roofs with gaps in the decking such as plank decks, insulation or recovery boards must be attached to the deck prior to membrane installation. This will eliminate the wash-board effect caused when the membranes are not fully supported with a smooth substrate. If insulation or recovery boards are used, follow the insulation manufacturer's instructions for proper installation.

positioning allows for 2 inches of membrane overhang to be wrapped over the edge and nailed off every 12 inches on both the horizontal and vertical surface of the deck and fascia, Rows A & B, while staggering the position of the nails as shown. Similarly, whenever a sheet ends at an edge, fold the sheet over the edge 2", cut off, and nail as you did with the edge of the starter sheet. The Kwik Base is cut off where it terminates into a wall or projection and should be cut as close as possible to the projection and nailed off at 6" intervals (cut off no more than 1/4" from the wall or projections). If two or more pieces of Kwik Base are necessary to accommodate the length, overlap 3 inches and nail along the end lap 9 inches on center.

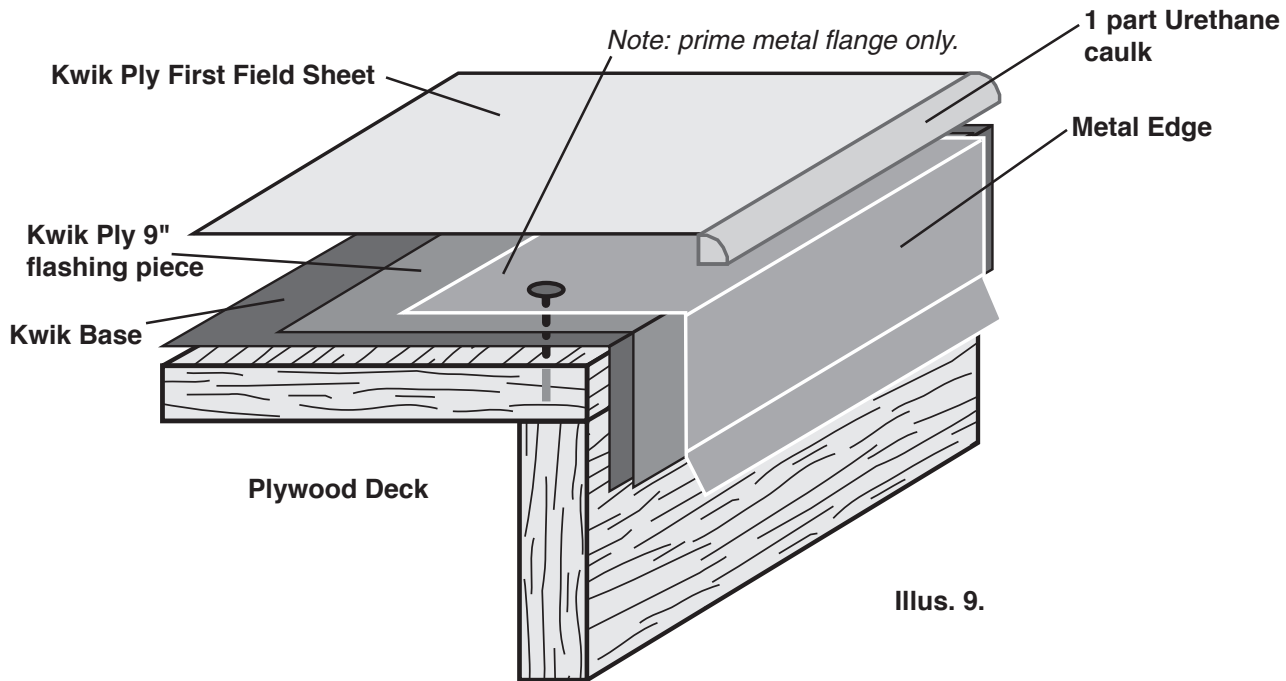

Illus. 9.

Strike another chalk line along the center of this base sheet—7 inches in from the roof edge is adequate (Nail row C, illus. 7) . Nail along that line on 12-inch centers. This spacing will require more fasteners per square, but this is a more critical area due to wind uplift. Take care not to create wrinkles or buckles in the membrane. Should they occur, cut along their length and nail in a staggered fashion 6 inches on center on each side of the cut.

You are now ready to install the second Kwik Base sheet which overlaps the starter sheet by 3 inches, if base sheet is Kwik Base, other base sheets may have different lay line dimensions. If no lay line is on the starter sheet, because you cut it off, strike a chalk line 3 inches in from the roof side of the sheet and along the entire length of the starter sheet. Now position the second base sheet along this line and nail along the 3-inch lap on 9" centers. Shown in illustration 7 as row D. Make sure nail heads are no more than 1/2 inch from the membrane edge.

To position additional nails in 2 rows along the center area of the base sheet, strike 2 chalk lines — shown in illustration 7 as rows E & F with the dimensions indicated on the illustration. Make the fastener placement in a staggered pattern as shown. Fasteners at perimeters, projections or at changes in deck direction should be spaced at 6-inch intervals—shown as row J.

Note: Place metal flashing reinforcement —shown in Shingle Tie-in illustration 12 as item A, before laying base sheet over deck transitions.

To achieve higher wind uplift values, decrease spacing between fasteners and add additional fasteners in corner areas.



Illus. 8.

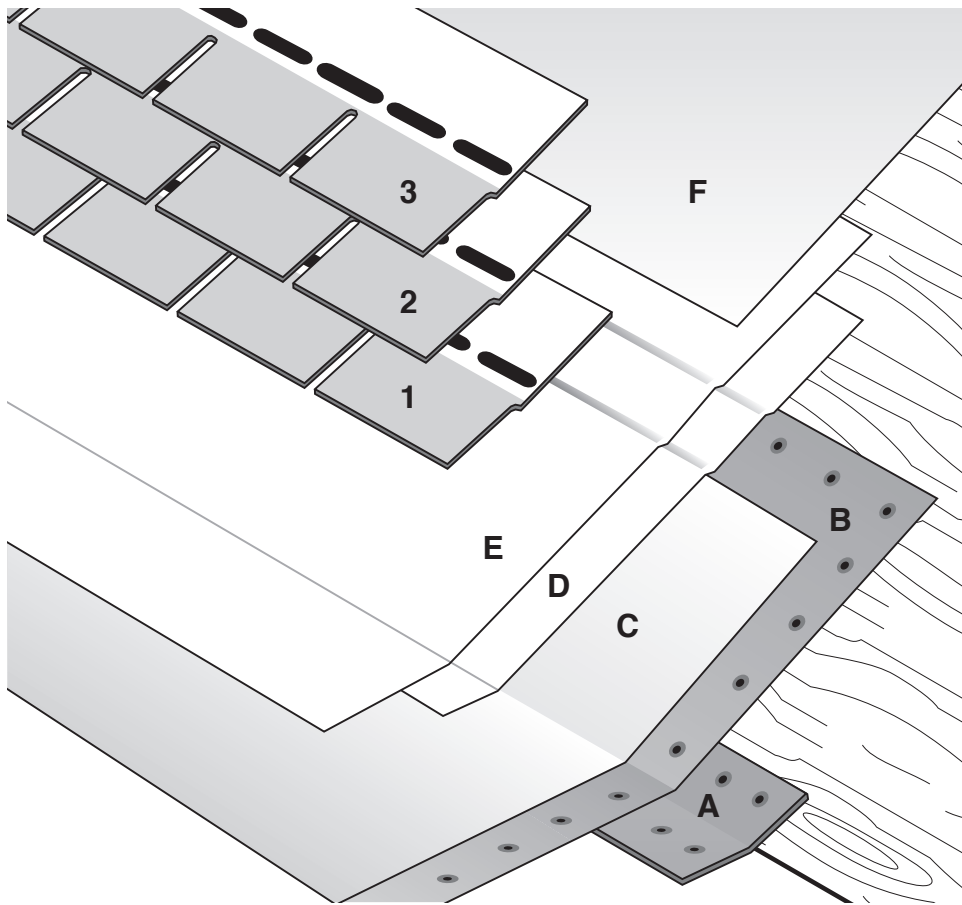

**Shingle Tie In
Illus. 12.**

A detail for tie in to shingle areas is provided in illustration 12. It will be necessary to remove at least 3 rows of shingles from the roof to install a proper tie in. Remove the shingles carefully if you want to use them again (you will have to reinstall or replace the shingles when all the membranes have been installed). The common tool used—easily rented or borrowed from a roofer—is a flat bar with a hook at one end and a raised area on the other end for striking with a hammer—shown in illustration 13.

Insert the tool under the shingle and align with the nail so that the hook catches on the nail. Then strike the other end of the tool with a hammer until the nail is pulled out or cut. Follow this procedure for each nail.

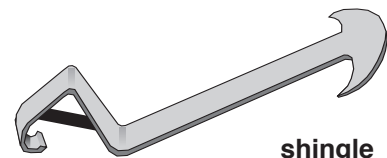

**shingle
nail remover
Illus. 13.**

Take care not to damage the existing old felt underlayment shown as F in illustration 12. This underlayment must overlap the Kwik Ply flashing as shown in E, illustration 12. Since this detail is at the top of the slope and the membranes are installed from low to high, we will cover the Kwik Ply installation in this area later in the guide.

At the change in deck angle it is prudent to nail a metal piece similar to that used to line valleys on steep slope roofing. It is shown in illustration 12 as A. Purchase this at your local roofing or building center. Nail the metal along both edges at 6 inches on center and make sure it conforms to the roof line and does not tent. Install tight to deck. Install metal piece A illustration 12 prior to installation of the Kwik Base course covering it. Install the last courses of Kwik Base over the metal piece A of illustration 12.

The Kwik Ply must now be installed from the low point on the roof up so that the Kwik Ply membrane will also be overlapped in a shingle fashion.

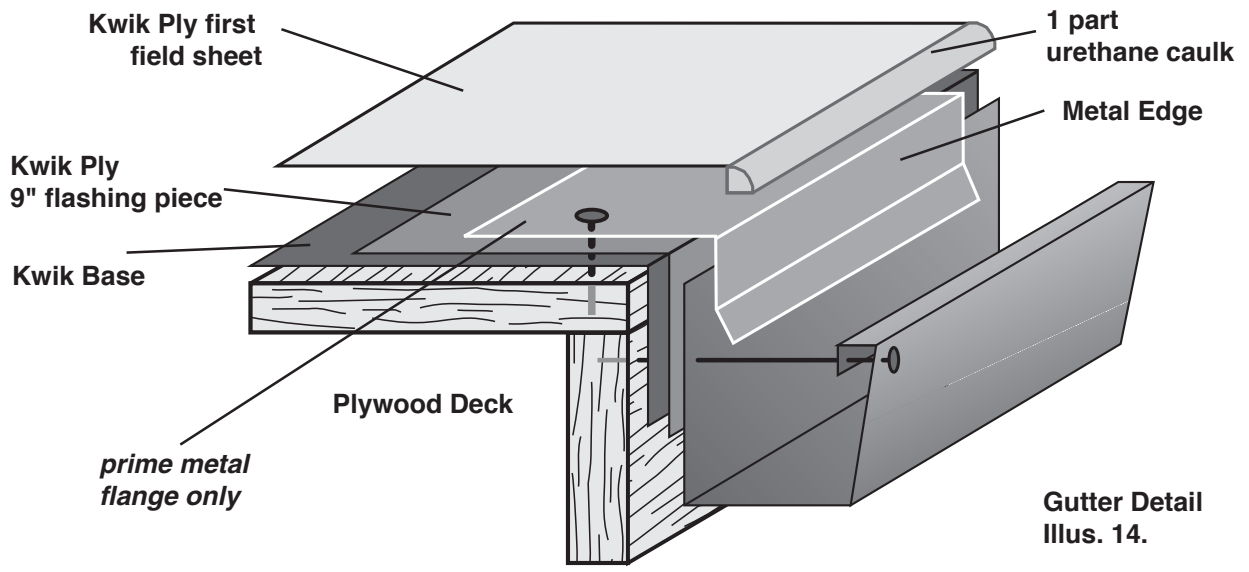

**Gutter Detail
Illus. 14.**

Installation of the gutter and the metal edges must be completed at this time, over the 9-inch-wide strip of Kwik Ply you have already installed, see illustration 14 -Kwik Ply gutter detail. There are too many gutter styles available to cover in this guide. Most residential applications use a gutter that is attached with a ferrule and spike. Shedding of the water from the roof into the gutter is accomplished with a metal flange or metal edge—see illustration 14.

In this gutter detail, the gutter is installed after the 9" strip of Kwik Ply is in place, and then the metal edge is installed so that the lower flange laps over the back of the gutter. The metal edge is nailed with large head roofing nails in a staggered fashion into the roof deck with nails spaced 6 inches apart. When nailing, make sure that the metal is not deformed and use fasteners made of the same material as the metal edge. At this time, prime the metal edge area using an ASTM D-41 quick drying primer, brush applied. Make sure the primer is dry before applying the Kwik Ply to it.

Layout of the Kwik Ply on the roof in a picture frame method is required—see illustration 15. The field plies are first installed up the center of the roof, but do not extend to each wall on the left or right side. Note that on both sides of the roof area, there is a membrane installed 90 degrees to the field plies. This is the picture frame membrane and its installation in this way is important. It should overlap the field sheets by 6 inches.

**Terminate
Picture Frame
at top of last
Field
Ply installed.**

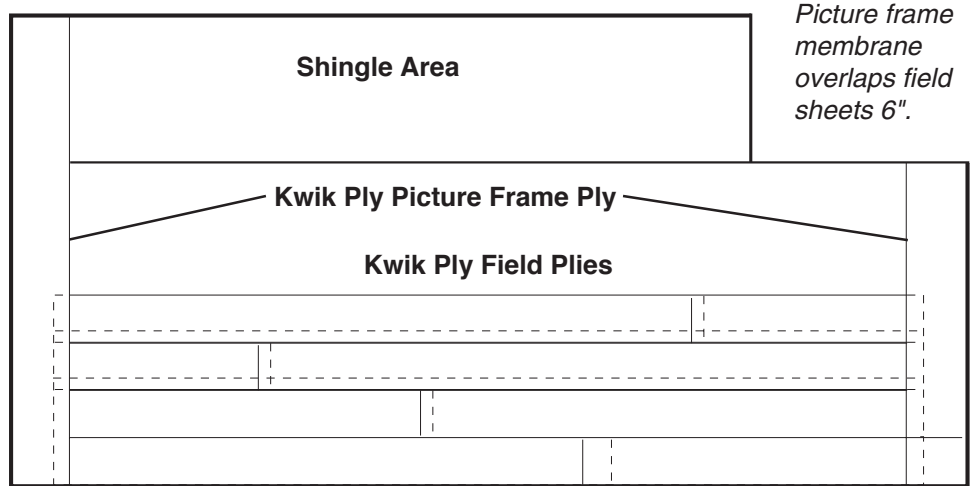

*Picture frame
membrane
overlaps field
sheets 6".*

Illus. 15.

— 4' min —

KWIK PLY INSTALLATION

Before installing any self-adhered membrane such as Kwik Ply, the substrate surface must be completely dry (sweep the surface to remove any loose objects, debris, etc.) and then prime with a quick drying ASTM D-41 primer, including all flashing areas. Apply with a paint roller using the dip and roll method as in painting applications—see illustration 8. The primer prepares the surface and neutralizes any manufacturing oils or talcs that are necessary in packaging. One gallon will normally cover 150-200 square feet.

Primer must be dry before applying Kwik Ply. Drying time will vary depending on substrate type, ambient temperature and humidity... typically 2 hours on a 59°F day for a quick dry primer. Test by pressing your thumb into the surface, twisting and then holding it in position for 30 seconds. When you remove your finger, no primer should be on it.

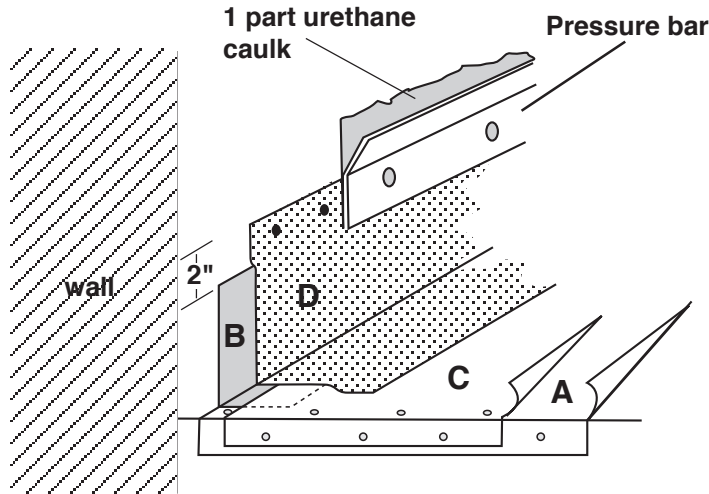

Illus. 10.

- A. Kwik Base installed to within 1/4 inch of wall and extending over edge (not shown).
- B. Kwik Ply first flashing piece installed 3" to 4" onto roof & up wall to within 2" of final flashing piece D.
- C. Picture frame Ply. See illus. 15.
- D. Kwik Ply final flashing piece D, height to be determined by building construction, must be extended onto roof 6" to 8".

Never apply primer by either pouring on the substrate and rolling, or by pouring and using a squeegee to spread. These methods will result in too heavy an application and will extend drying time considerably. They also increase the chance of trapping primer that has not dried under the installed membrane, which could result in eventual blistering or wrinkling of the membrane.

With the primer now dry, you are ready to apply the Kwik Ply, starting with the flashing areas at the perimeters. At the metal edge or gutter area, a strip of Kwik Ply must be applied along this edge... usually a 9-inch-wide strip is sufficient. Strike a chalk line on the base sheet 7" in from the edge of the roof and parallel with the roof edge. Install the 9" wide strip along this edge using the chalk line to align layout. This will give you the 2" overhang required. See illustration 9.

At wall areas of both masonry and wood construction, to determine the width of the first and final flashing pieces, (see D illustration 10) the termination point on the wall must be determined. This is the point where the pressure bar installation or nailing off of the membrane is located. For the first flashing piece, make a mark 2" below the termination point, measure from that mark down the wall and out onto the roof 4". This measurement is the width of your first flashing piece. See illustration 10, membrane B.

For the final flashing piece, measure from the termination point and out onto the roof 6" to 8". This measurement will be the width of your final flashing piece. Note that this piece will be installed after the picture frame membrane is installed. See illustration 10, membrane D, also corner detail is shown in illustration 24 and 25.

illus. 11.

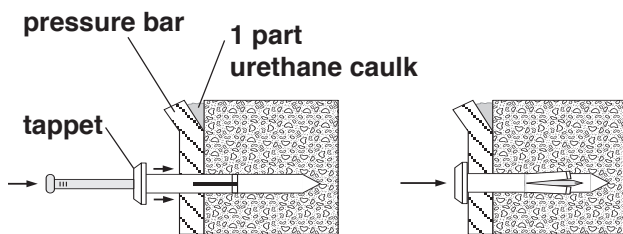

The only difference in flashing masonry versus wooden walls is that fasteners used to hold the pressure bar to masonry are tappets instead of wood screws. Their holes must be pre-drilled into the masonry (see illus. 11). with a hammer drill using a masonry bit appropriately sized for the tappet. Purchase the bit at the same time as the fasteners, this will ensure a proper match of fastener to drill bit.

To accomplish this 6-inch overlap, measure out from the wall 30 inches at the top and bottom of the slope and mark. Now strike a chalk line between these 2 points. The line should be 30 inches from the wall and parallel to it. Now do the same procedure on the other roof side. Then the Kwik Ply membrane is installed in a shingle-like fashion between the 2 lines. When the 36-inch picture frame membrane is installed on both roof sides, the necessary 6-inch overlaps will be in place.

LAYING THE MEMBRANE

When laying the membrane, be sure to follow these instructions. They are not complicated and are designed for you to produce a finished roof that will provide weatherproofing protection for years to come. It is easy to get ahead of yourself, so go at a pace that permits you to follow these procedures in the proper sequence.

Place a mark 36-1/2 inches on each side of the roof as measured from the roof edge, or metal edge or gutter edge. Strike a chalk line between these marks and this will serve as your first lay line (this provides a 1/2-inch inset from the metal edge; see illus 16).

Now place the Kwik Ply roll so that the end of the membrane touches the chalk line struck to effect the picture frame membrane overlay (illus. 15). Roll out about 6 feet of membrane and align with the chalk line struck as the first lay line. Next, use a sharp utility knife to cut the release paper along the top of the roll. Take care not to cut into the roll or adhesive. When cutting membrane do not use the surface of roof as a cutting board; use a piece of masonite or plywood as cutting board.

After cutting release paper, fold over about 2 inches of release paper on each side of the cut. The release paper on the top side will be used to pull the roll along the lay line (illus. 17). Roll up the excess paper on an old roll core to make disposal of the paper easier. When

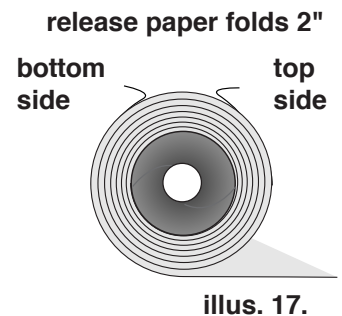
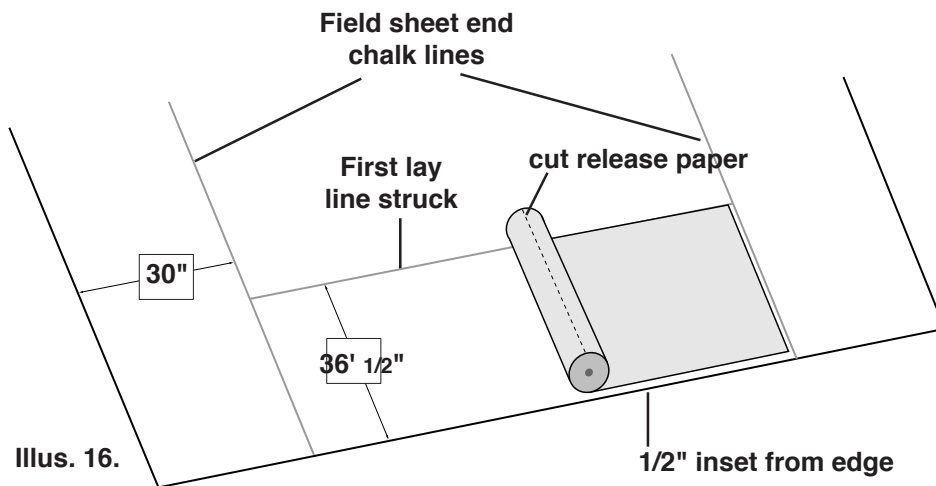

you reach the end of the area to be covered (field sheet end chalk lines, illus. 16), cut off the roll at the opposing chalk line termination. With a course now completed, inspect the installed area for air pockets or wrinkles and broom out and roll out with a 70 lb. linoleum roller or equivalent. Trapped air which can cause blisters, should be minimal if you broom lightly as you roll each three or four feet of membrane out.

As you are placing the membrane, take care to follow the lay lines and after 3-4 feet of membrane are in place, broom lightly from the center of the membrane to the edges and smoothly fit the membrane to the surface. Light pressure should be used as the object is to create a smooth membrane surface, not to set the membrane which is done with a 70-lb roller or garden roller of the same weight. (illus. 18)

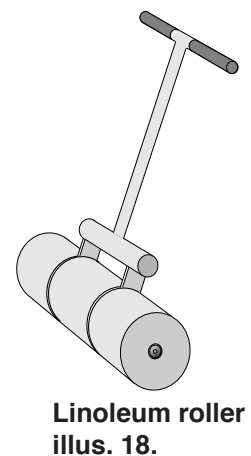

installed only on the low slope portion of the roof. As this is a transition area, the Kwik Ply membrane installed at the metal edge and extending 18" into the area at the base of the slope, is overlapped by the second piece, or the course going up the sloped shingle area, giving added strength and more effective waterproofing. The last course to be installed in the field of the roof is depicted in illustration 12 as membrane C.

Before installing the picture frame membranes, it is necessary to caulk the "T" joint areas on both field sheet ends—see illustration 17. Use a 1-part urethane sealant and caulk the lap lines from the end of the field sheets 6 inches into the field sheets, or to a point where the side lap of the picture frame membrane will end on the field sheet. It is also necessary to install the first flashing piece illustration 10 membrane B before installing the picture frame membrane. This procedure was outlined earlier in the guide on page 8.

A 1/4-inch bead should be sufficient for all membrane caulking details. Also caulk along the entire end of the field sheets on both sides. Since the picture frame membrane bridges over the field sheet laps, a small void is possible and the caulk is a precaution to eliminate those voids where moisture could enter the assembly.

Now install the picture frame membranes on each side of the roof. They should extend from the base of the wall out onto the roof 36 inches and overlap the field sheets by 6 inches. They also extend from the point shown in illustration 15 where the top edge of last field sheet terminated down to where the first field sheet began (1/2 inch from the roof edge on the metal).

Now install the final flashing pieces as shown in illustration 10, membrane D These pieces should extend out onto the roof at least 6 inches and up the wall to where they will be terminated with a caulked pressure bar or nailed off under the protection of siding or other counterflashing detail. Before installing the flashing pieces, caulk the last 2 feet at the bottom of the slope at the base of the wall.

At the shingle tie in begin the first flashing membrane at the point where the top of the second shingle is positioned (membrane D, illus. 12) and will extend onto the low slope roof at least 4 inches. Begin the final flashing piece (membrane E, illustration 12) at the shingle tie in at a point where the top of the third shingle is positioned and will extend onto the roof at least 8 inches.

SOIL STACK DETAILING

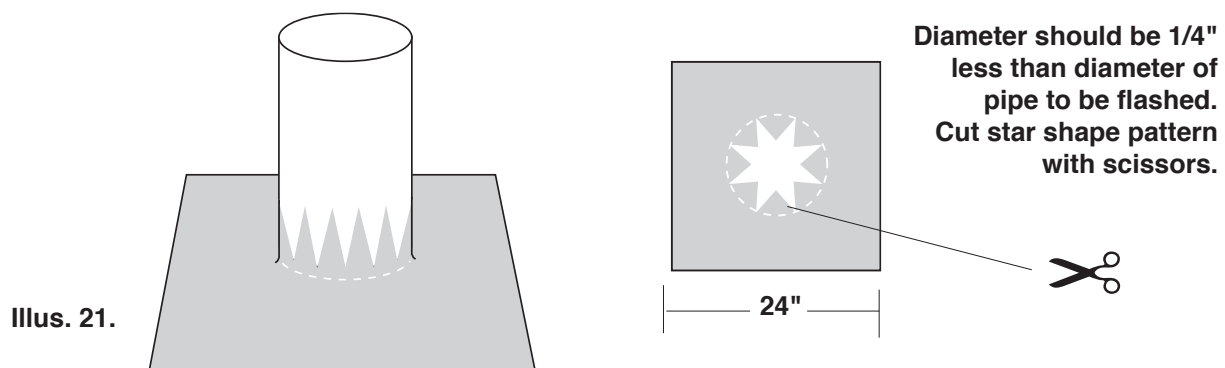

A soil stack is a common penetration through the roof and is shown in illustration 21. This projection is sealed by cutting a square sheet of Kwik Ply about 2' x 2' and marking a serrated circle in the center about 1/4 inch smaller in diameter than the pipe you are sealing. As shown in the illustration, cut serrations in the center of circle. Leave the release paper on the piece and pull the piece over the top of the pipe. When the piece is positioned, remove the release paper and set the flashing piece with a hand roller.

Now cut a piece of membrane 2 inches larger than the circumference of the pipe and 8 inches in height—less if the pipe is shorter. Wrap the piece around the pipe so that the base of the piece covers all openings at the base of the pipe where the star cuts were made. Do not stretch this piece when installing. Place a clamp 1/4 inch from the top of the membrane and caulk both top and bottom of the pipe as shown with a one-part urethane caulk. See illustrations 22 and 23.

Caulk the membrane edge where it terminates at the metal edges and other areas where the membrane will buck water. Check corners and caulk where necessary. Caulk the top of all termination bars installed, again using a one-part urethane.

A coating can be applied to the installed Kwik Ply membrane, although not necessary. It usually is best to wait until the following year. Purchase a fibrated, aluminum coating containing two pounds of aluminum. Coatings are normally sold in five gallon containers. If a color is desired, use an acrylic coating with low oil content; however, it will need to be coated more often.

Kwik Ply membrane should be cut 2" longer than the circumference of the pipe.
Do not stretch piece when installing.

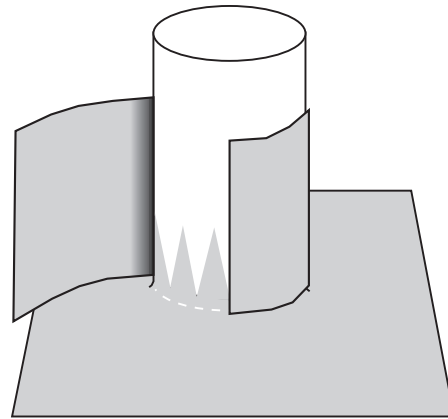

Illus. 22.

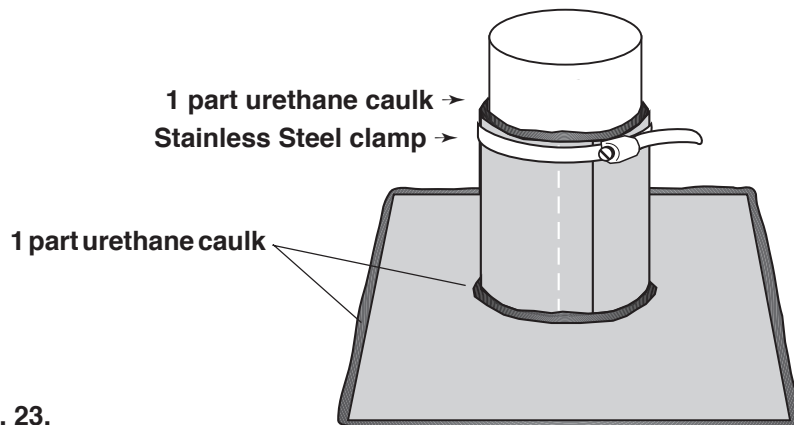

Illus. 23.

**"T" Joint Detail
Illus. 19.**

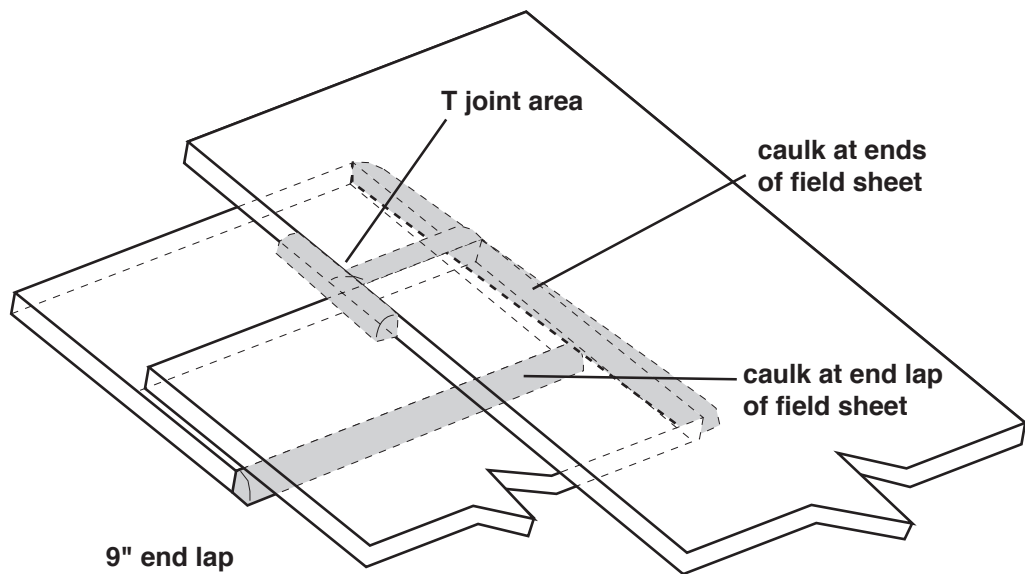

You still have about 6 feet of membrane left with release paper on it. Roll this section up towards the already installed portion, remove the release paper by pulling on the folded over part you created when first cutting the release paper. Apply the same brooming and rolling methods you used when installing the first part of the membrane.

The second course is installed just like the first course except instead of the chalk line, you may use the painted lay line to align the membrane along its edge. The painted lay line on the Kwik Ply aligns the membrane courses in equal fashion and creates the 3" membrane overlap which is an important part of Kwik Ply's waterproofing protection.

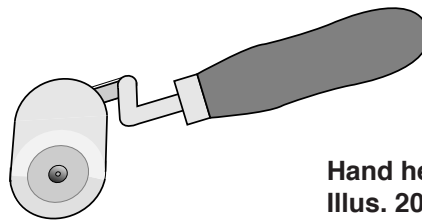

**Hand held roller
Illus. 20.**

When 2 pieces of membrane are used to finish a course, overlap the ends of the membrane 9". This will also create a T joint which requires caulking before overlapping the membranes, and is shown in illustration 19. End laps in the various courses must be staggered by at least 4' as shown in the picture frame illustration 15.

ROLLING THE MEMBRANE

As membranes are laid and broomed in, a 70-lb roller (illus. 18) must be run over the surface to firmly adhere the membrane in place. This procedure should be done as every 2-3 courses are installed, blowing dust or lengthy exposure of the adhesive to air could cause lap contamination. Since lap sealing is an important part of the waterproofing protection, you should give special attention to it. Recommended is the use of a smaller hand-held roller to apply pressure to the lap areas and is shown in illustration 20.

Continue applying courses up the slope until you arrive at the shingle tie in and metal edge at the high point of the roof. As in all metal edge details, the membrane is held back from the edge by 1/2 inch and caulked. You may elect to install 2 membrane pieces in this area, one at the metal edge extending over into the area just below the slope by 18" and

CORNER DETAILS FOR FLASHINGS

The corner details for flashings are addressed in the following illustrations and descriptions. They are described separately in this guide so that flashing installation will be easier for the applicator.

The flashing pieces and their width as previously described in Illus. 10 - B First flashing piece, and Illustration 10 - D Final flashing piece, must be formed to fit inside and outside corners when a 90° angle is encountered on a wall flashing. Keep in mind that the height of the finished flashing should be a minimum of 8" and that flashings should be installed from the low point of the roof up the slope, the same as the felts are laid, and in a shingle fashion using a minimum of 4" overlaps. Make sure that the walls you will be adhering to have been primed and that they are dry.

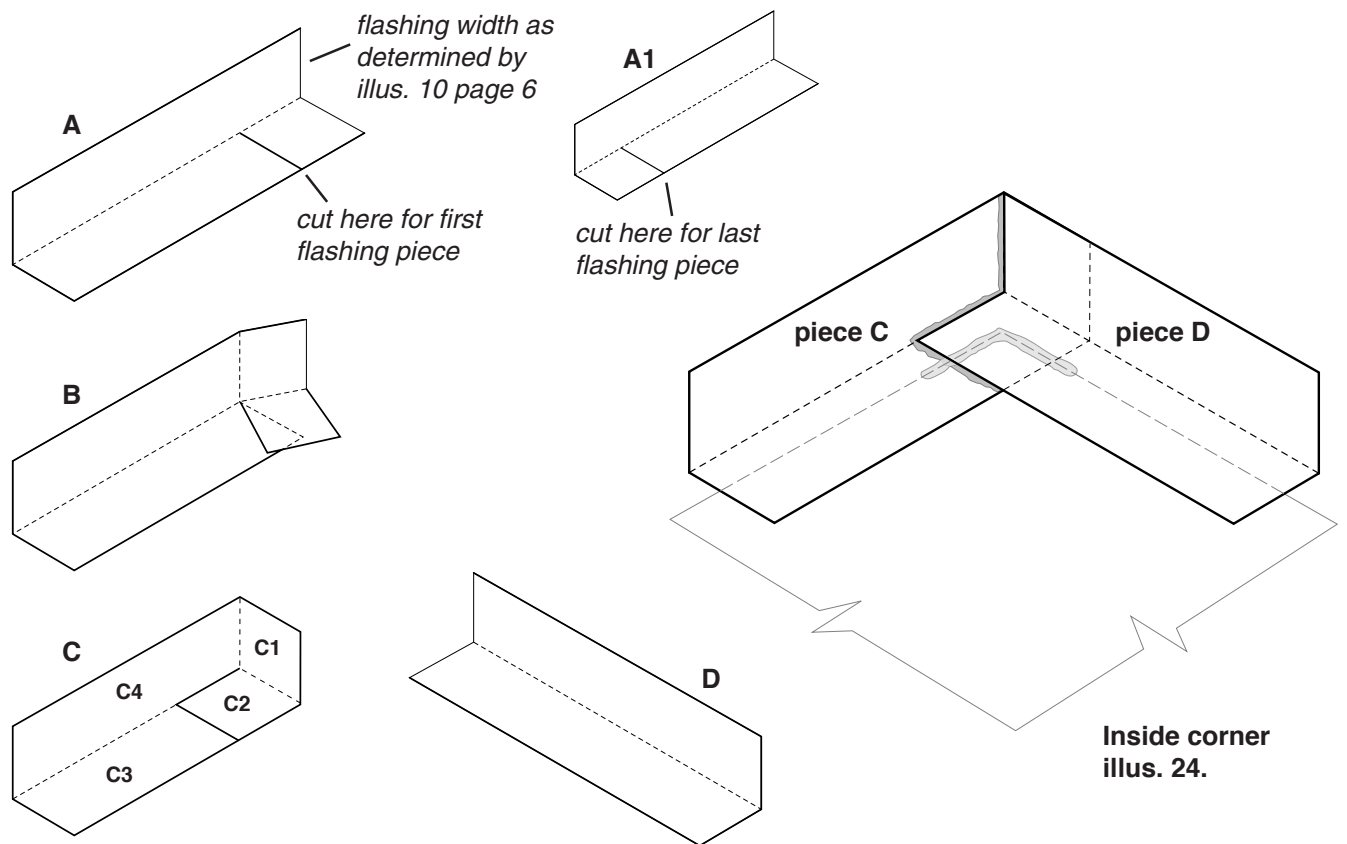
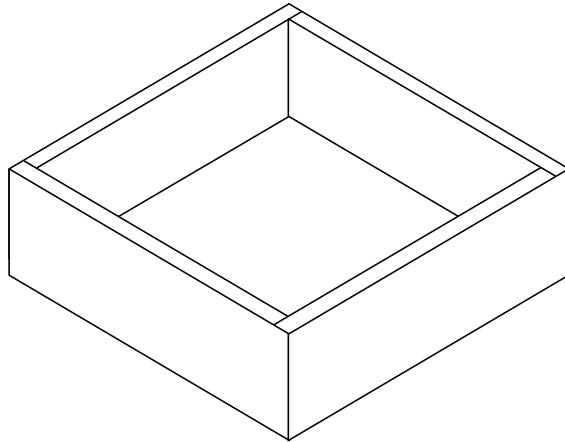

Illustration 24 drawings depict an inside corner fabrication, A - represents the flashing piece cut and folded to the dimensions as determined in Illustration 10. The piece could be either Illus.10- B, First flashing piece (narrower piece), or Illus. 10-D the Final flashing piece (wider piece). It is easier to fabricate and install fabricated corner flashing pieces when they are shorter in length. Use lengths of 1 to 2 feet maximum.

As shown in A, cut the membrane at a point 4" in from the end of the piece to enable you to fold the membrane as shown in B. When folded, the release paper can be removed from the membrane under C1 and adhered to C-2. Using a sharp knife, kiss cut the release paper at all of the folds in the membrane and fold the release paper back about 1". Make sure you do not cut into the adhesive or the membrane as this will result in splitting of the membrane at these points.

SKYLIGHT OR EQUIPMENT STANDS

It is recommended that the height of the curbs on these types of projections be at least 8" above the roof surface. As these types of details are usually areas subject to annoying leaks, give consideration to raising the height of existing curbs if the existing curbs are below the 8" height recommended. In illustration 26 below, a typical curb for these types of roof accessories is depicted.



illus. 26.

For flashing this detail refer to the wall detail in illustration 25. For flashing height, the final flashing piece should extend over the top of the curb and nail off at 4" centers. If this is not possible, a pressure bar as shown in illustration 10 must be installed.

LIST OF TOOLS

Following is a list of tools that should be available when you start the project.

1. Razor Knife
2. Chalk Line
3. Tape Measure
4. Light colored crayon, and pencils.
5. Linoleum or water filled garden roller 70 lbs.
6. Hand Roller
7. Straight Edge 4' long
8. Caulking gun
9. Hammer
10. Gloves
11. Eye Protection
12. Saw
13. Pry Bar
14. Tin Snips
15. Hammer Drill
16. Masonry bit sized for fastener purchased.
17. Paint roller, pan, handle extension, extra roller cover
18. Scissors
19. Flat blade shovel for removing old roof

Appendix A

PRIMERS - ASTM D41 (Quick Dry)

ALCM	800-556-8030
Brewer Co.	216-944-3800
Gibson-Homans	216-425-3255
Gulf States Asphalt Co.	713-941-4410
Henry Co.	800-598-7663
National Coatings Corp	805-388-7112
Schuller Roofing Systems	800-654-3103
Texas Refinery Corp.	800-827-0711

FASTENERS, NAILS (Wood Deck)

Building Products of America Corp	516-568-0222
Celotex Corp	813-873-4103
Cleasby Mfg Co.	415-822-6565
Markwell Mfg Co.	617-769-6610
Maze Nails	800-435-5949
National Nail Corp	800-746-5659
Roofmaster Products Co.	213-261-5122
Senco Products Inc.	513-388-2000
Whitford Corp	610-296-3200

BASE SHEETS

Celotex Corp	813-873-4103
Fields Corp	206-627-4098
GAF Materials Corp	201-628-3000
Globe Building Materials Inc.	800-950-4562
Intec/Permaglas	800-231-4631
Owens Corning	419-248-8000
Schuller Roofing Systems	800-654-3103

CANT STRIPS

Cal Cant	909-350-2286
Cant Products Inc.	800-282-4482
Celotex Corp	813-873-4103

CEMENT, Flashing

ALCM	800-556-8030
Brewer Co.	216-944-3800
Celotex Corp	813-873-4103
CIM Industries Inc.	800-543-3458
Fields Corp	206-627-4098
GAF Materials Corp	201-628-3000
Gibson-Homans	216-425-3255
Grundy Industries Inc.	815-726-5087
Gulf States Asphalt Co.	713-941-4410
Henry Co.	503-288-5454
National Coatings Corp	805-388-7112
Palmer Asphalt Co.	800-352-9898
Revere Products	800-321-1976
Schuller Roofing Systems	800-654-3103
Tropical Asphalt Products Corp	954-983-3434
Uniflex, Industrial Div Kool Seal Inc.	800-321-0572
J C Whitlam Mfg. Co.	330-334-2524

CURBS

Custom Curb Inc.	423-629-6241
Pate Co.	800-243-3018

DRAINS & STRAINERS

Alumax Home Products	800-776-8629
Frey Co.	708-344-6690
Josam Co.	219-872-5531
Marathon Roofing Products Inc.	716-685-3340
U Flow	716-854-1521
Zurn Ind., Inc./Hydromechanics Div.	814-455-0921

FASTENERS, SCREWS, Masonry

Hilti Inc.	800-879-8000
ITW Buildex	708-595-3500
Olympic Fasteners	800-633-3800
Rawlplug Co.	914-235-6300
Tru-Fast Corp	419-636-6715

EDGE STRIPS

Alumax Home Products	800-776-8629
Appleton Supply Co.	414-733-1373
Cal Cant	909-350-2286
Continental Materials inc.	215-884-4930
Flamco	904-783-8400
Flashmaster inc.	314-731-2465
Guttermaker Inc.	313-848-8865

SEALANTS, Urethane

CIM Industries Inc.	800-543-3458
Gulf States Asphalt Co.	713-941-4410
Sika Corp (Sonneborn)	816-923-8200

SHEET METAL, Pitch Pans

Metal-Era Inc.	414-549-6900
Portals Plus Inc.	800-774-5240
RoofMart Intl Inc.	800-ROOF-RMI

SURFACE MOUNTED COUNTER FLASHING

Flashmaster Inc.	314-731-2465
MEC/Advanced Modified Systems	312-685-1012

TERMINATION BAR, ALUMINUM

Metal-Era Inc.	414-549-6900
Petersen Aluminum Corp	800-323-1960
Roofmaster Products Co.	213-261-5122
Tru-Fast Corp.	419-636-6715
Olympic Fasteners	800-633-3800

TOOLS, Roofing Seaming Rollers

Cleasby Mfg Co.	415-822-6665
Everhard Products inc.	330-453-7786
Flame Engineering Inc.	800-255-2469
Frey Co.	708-344-6690
Roofmaster Products Co.	213-261-5122
United Construction Products Inc.	800-333-4234
Gundlach Co.	618-233-1781

HOT AIR BLOWER

Primus	815-332-5504
--------	--------------

Using 1 part urethane, caulk the corner area about 4" along the intersection of the roof and wall, also up the wall as high as the flashing piece being installed. Adhere flashing piece C in place. Start in the corner and work out taking care not to leave wrinkles in the membrane.

The second or final flashing piece installed after the picture frame membrane is installed is done the same way with one exception. The tabs should be reversed so that a thick membrane buildup on one side of the corner will be avoided. You will make a piece similar to formed piece C but the cut and resulting folds would be made on the other end of the piece as shown in Illus. 24 A.

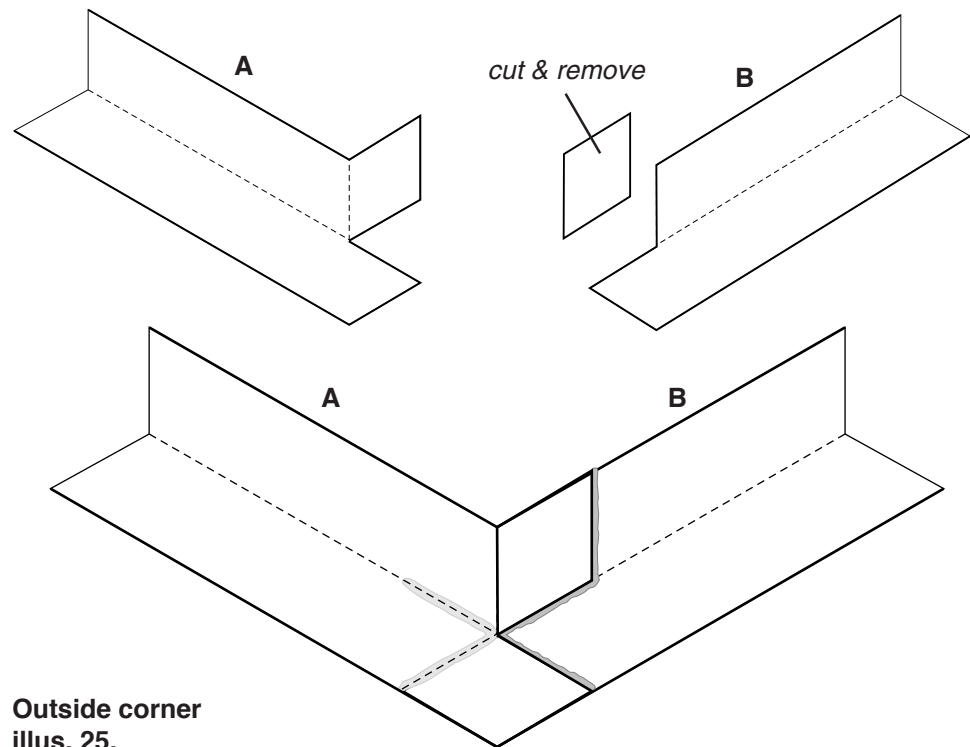

**Outside corner
illus. 25.**

Outside corners Illus. 25 are simpler to make and install and referencing the procedures above, and illustration 25, will be adequate for fabricating and installing these flashing pieces. These pieces are used to flash around outside corners, typically roof curbs on which air conditioning equipment or skylights are set. They are normally formed one piece to a side but can be installed in two pieces. As these units are usually in the field of the roof, make sure when installing the flashing pieces that the laps do not buck against the normal flow of rainwater being shed off of the roof area. Caulk those laps with one part urethane if there is a question about there bucking rainwater.

NOTES

NOTES

Warnings and Cautions

This Application guide is not intended to be a safety manual. Installer is responsible for compliance with all applicable building and safety codes. Installer must also strictly adhere to each manufacturer's safety standards regarding tools, equipment and materials utilized in the performance of the installation.



9976 Rittman Road
Wadsworth, OH 44281
Ph. 800-457-4056
Fax 330-336-5512

Warnings and Cautions

This Application guide is not intended to be a safety manual. Installer is responsible for compliance with all applicable building and safety codes. Installer must also strictly adhere to each manufacturer's safety standards regarding tools, equipment and materials utilized in the performance of the installation.



9976 Rittman Road
Wadsworth, OH 44281
Ph. 800-457-4056
Fax 330-336-5512