

# HYLOAD CTEM WATERPROOFING WS

DATA SHEET

## WELDED SEAM

# WATERPROOFING DETAILS

# HYLOAD CTEM WATERPROOFING WS

DATA SHEET

## WELDED SEAM

# WATERPROOFING DETAILS

### Membrane Thru Key Joint

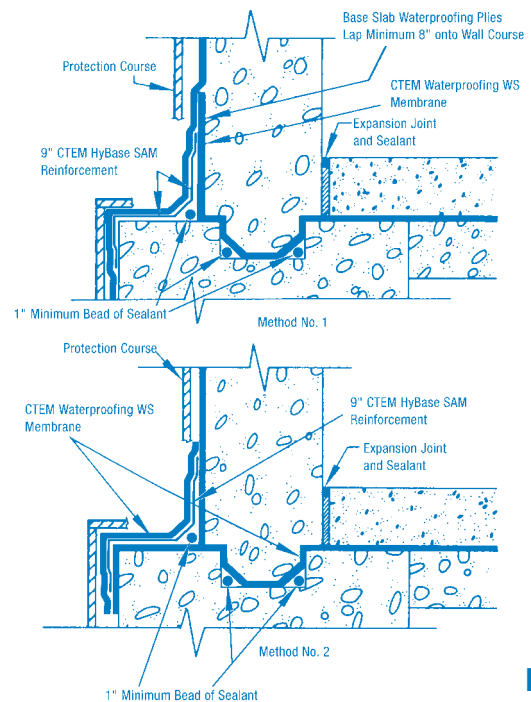

### Waterproofing Between Slabs

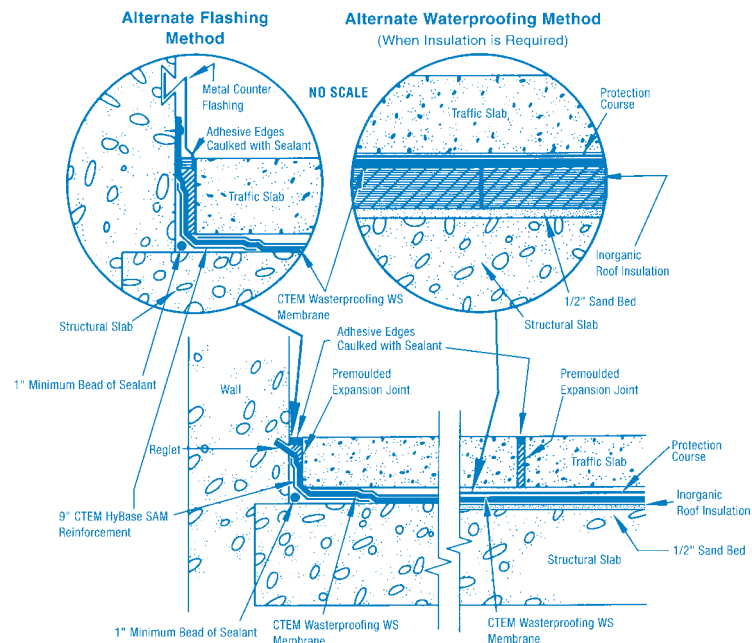

### Reflecting Pool Flashing

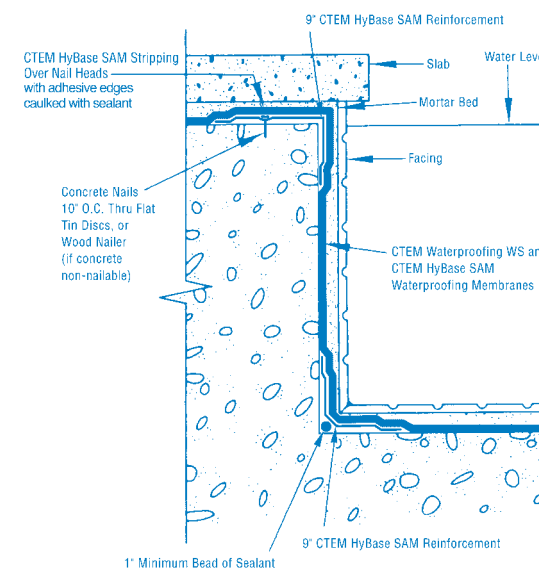

### Sump Detail for Reflecting Pool

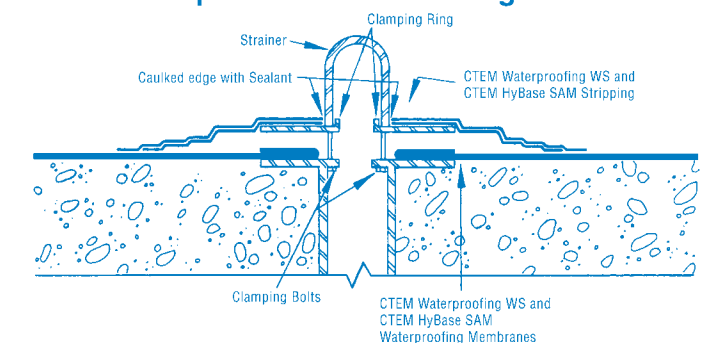

### Protected Membrane Roof Assemblies (PMR)

#### Hyload CTEM Waterproofing WS

#### Vegetative / Planted PMR Assembly

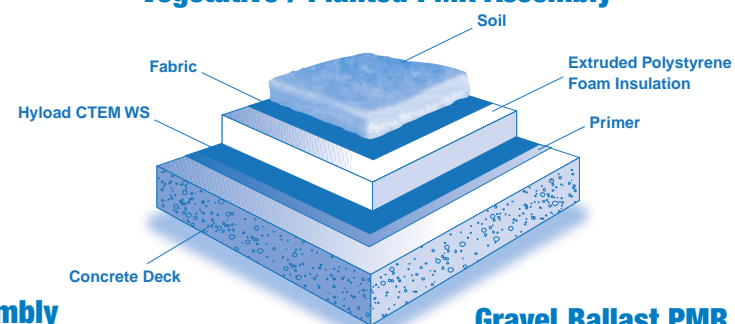

#### Roof Terrace PMR Assembly

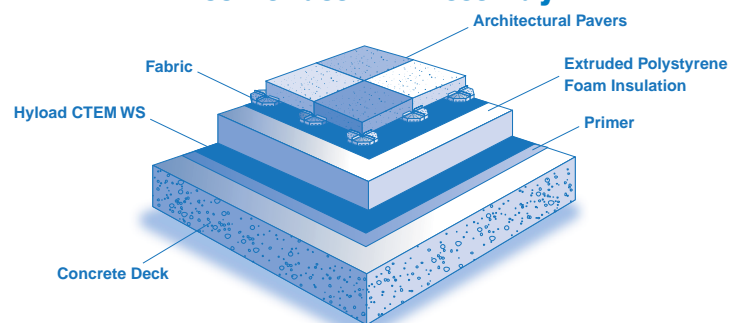

#### Gravel Ballast PMR Assembly

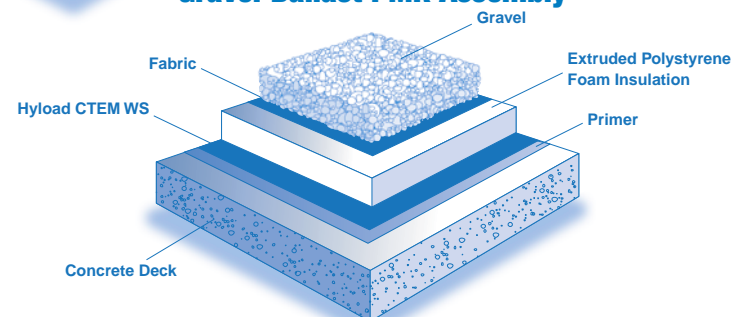

### Plaza Steps

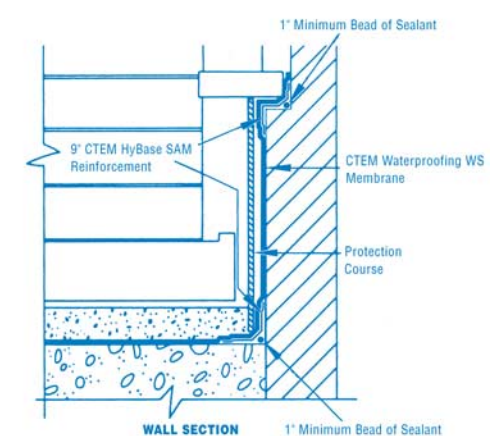
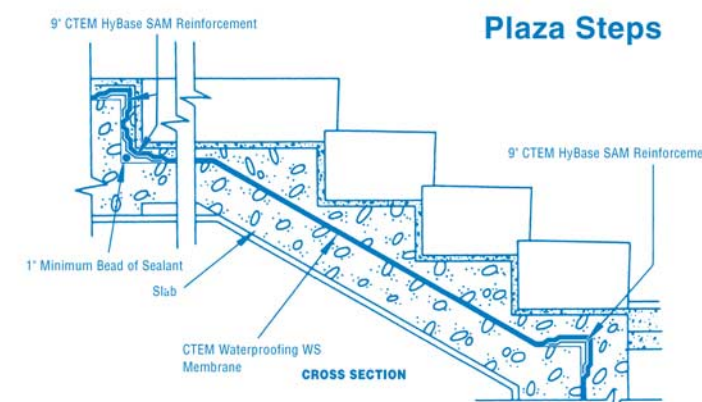

# HYLOAD™ CTEM WATERPROOFING WS

DATA SHEET

## WELDED SEAM

**HYLOAD**  
ROOFING SYSTEMS  
WATERPROOFING DETAILS

# HYLOAD™ CTEM WATERPROOFING WS

DATA SHEET

## WELDED SEAM

**HYLOAD**  
ROOFING SYSTEMS  
WATERPROOFING DETAILS

### Basement Waterproofing

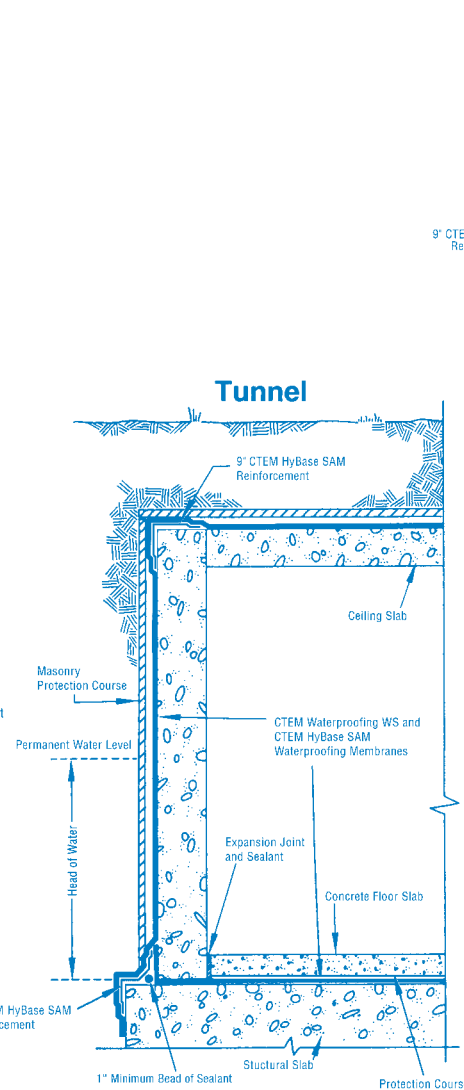
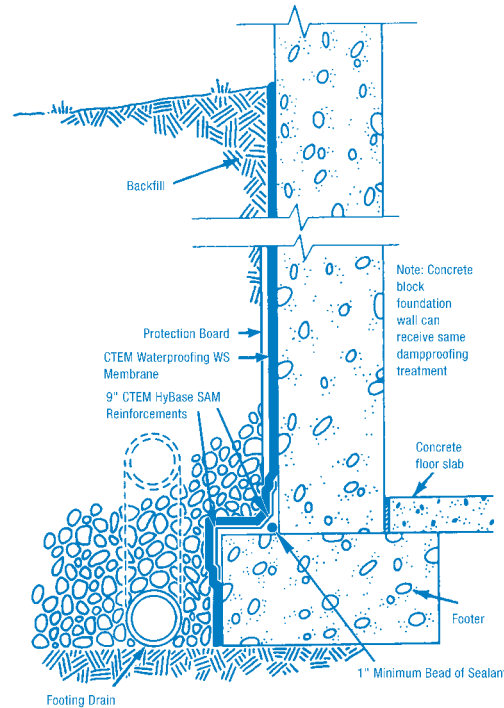

### Planter Box

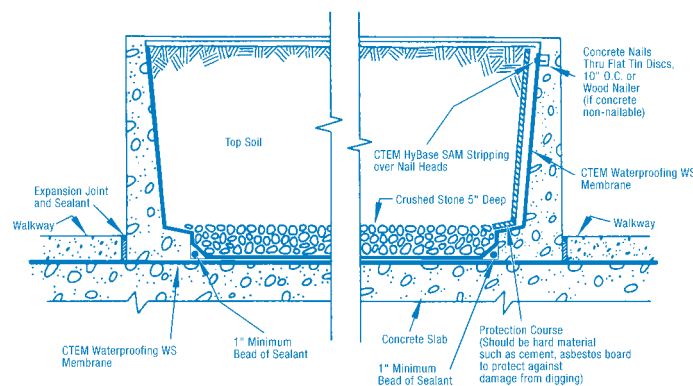

### Planter Drain

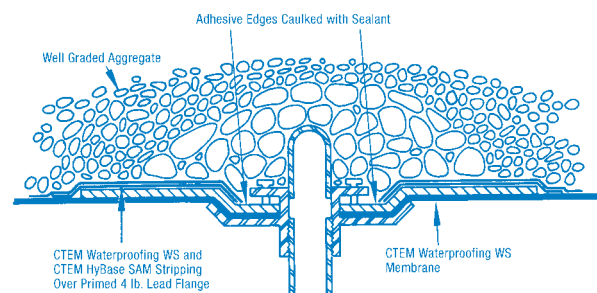

### Sidewalk Vault

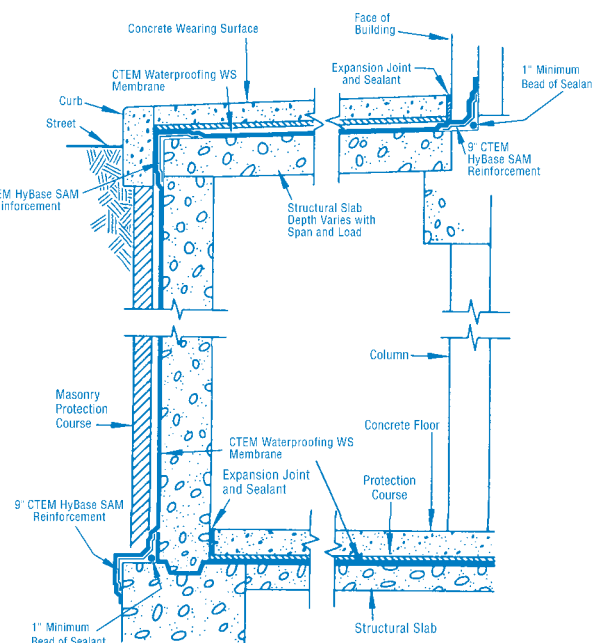

### Pipe Detail

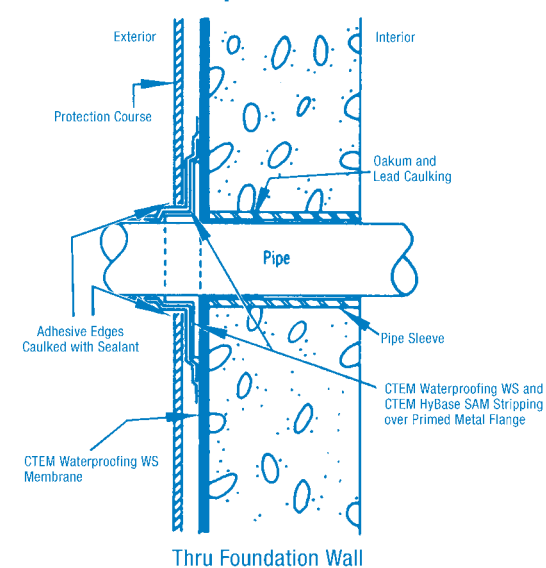

### Pipe Detail Thru Horizontal Slab

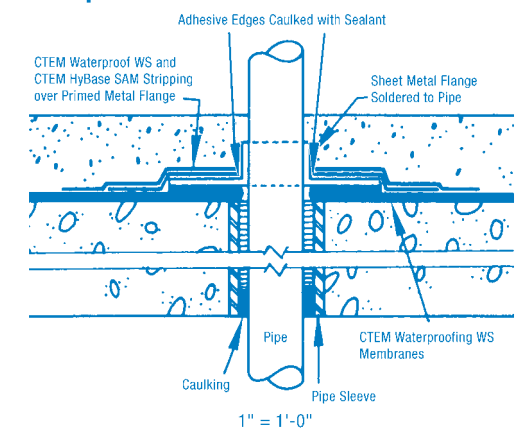

### Terminations of Membrane at Grade

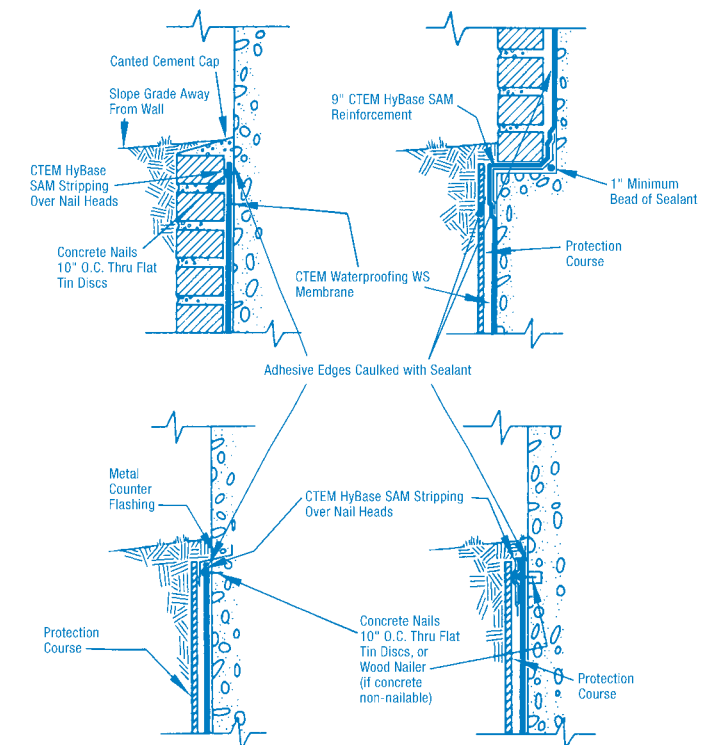

### Insulated Steam Pipe Detail

